



# IBM 10/100 乙太網路桌面配接卡系列

---

使用手冊

註: 在使用本資訊及其支援的產品之前，請先閱讀附錄 D 中 D-1 頁的“Product warranties and notices”。

---

# 目錄

安全 . . . . .	v
前言 . . . . .	vii
為您的選用設備註冊 . . . . .	vii
<b>安裝及使用手冊 . . . . .</b>	<b>1-1</b>
系統需求 . . . . .	1-1
Microsoft Service Pack . . . . .	1-1
Novell NetWare Support Pack . . . . .	1-1
安裝配接卡 . . . . .	1-2
連接網路接線 . . . . .	1-2
連接 Wake on LAN 電源線 . . . . .	1-3
安裝網路裝置驅動程式 . . . . .	1-5
Windows 2000 . . . . .	1-5
Windows NT 4.0 Workstation . . . . .	1-5
Novell NetWare 5.x . . . . .	1-6
其它的作業系統 . . . . .	1-7
製作磁片 . . . . .	1-7
附加的安裝及配置 . . . . .	1-7
<b>附錄A. 疑難排解 . . . . .</b>	<b>A-1</b>
PCI 架構設定的疑難排解 . . . . .	A-2
軟體更新網站 . . . . .	A-3
<b>附錄B. 配接卡規格 . . . . .</b>	<b>B-1</b>
<b>附錄C. Help and service . . . . .</b>	<b>C-1</b>
Online technical support . . . . .	C-1
Telephone technical support . . . . .	C-1
<b>附錄D. Product warranty and notices . . . . .</b>	<b>D-1</b>
IBM Statement of Limited Warranty . . . . .	D-1
Part 1 - General Terms . . . . .	D-1
Part 2 - Country-unique Terms . . . . .	D-4
Notices . . . . .	D-11
Processing date data . . . . .	D-12
Trademarks . . . . .	D-12
Electronic emission notices . . . . .	D-12
Federal Communications Commission (FCC) statement . . . . .	D-13



---

## 安全

在安裝之前，請先閱讀本產品的「安全資訊」。

مج، يجب قراءة دات السلامة

Antes de instalar este produto, leia as Informações de Segurança.

在安装本产品之前，请仔细阅读 **Safety Information**  
(安全信息)。

Prije instalacije ovog produkta obavezno pročitajte Sigurnosne Upute.

Před instalací tohoto produktu si přečtete příručku bezpečnostních instrukcí.  
Læs sikkerhedsforskrifterne, før du installerer dette produkt.

Ennen kuin asennat tämän tuotteen, lue turvaohjeet kohdasta Safety Information.

Avant d'installer ce produit, lisez les consignes de sécurité.

Vor der Installation dieses Produkts die Sicherheitshinweise lesen.

Πριν εγκαταστήσετε το προϊόν αυτό, διαβάστε τις πληροφορίες ασφάλειας  
(safety information).

לפני שתתקינו מוצר זה, קראו את הוראות הבטיחות.

A termék telepítése előtt olvassa el a Biztonsági előírásokat!

Prima di installare questo prodotto, leggere le Informazioni sulla Sicurezza.

製品の設置の前に、安全情報をお読みください。

본 제품을 설치하기 전에 안전 정보를 읽으십시오.

Пред да се инсталира овој продукт, прочитајте информацијата за безбедност.

Lees voordat u dit product installeert eerst de veiligheidsvoorschriften.

Les sikkerhetsinformasjonen (Safety Information) før du installerer dette produktet.

Przed zainstalowaniem tego produktu, należy zapoznać się  
z książką "Informacje dotyczące bezpieczeństwa" (Safety Information).

Antes de instalar este produto, leia as Informações sobre Segurança.

Перед установкой продукта прочтите инструкции по технике безопасности.

Pred inštaláciou tohto zariadenia si pečítajte Bezpečnostné predpisy.

Pred namestitvijo tega proizvoda preberite Varnostne informacije.

Antes de instalar este producto lea la información de seguridad.

Läs säkerhetsinformationen innan du installerar den här produkten.

安裝本產品之前，請先閱讀「安全資訊」。

---

## 前言

本手冊提供您安裝和使用配接卡所需的相關資訊。本手冊分成以下二個部份：

### 安裝及使用手冊

本手冊包括簡略的安裝說明。

本手冊具有下列語言的版本：

- 英文
- 法文
- 德文
- 西班牙文
- 義大利文
- 巴西葡萄牙文
- 繁體中文
- 日文

### 附錄

此一附錄包括產品規格、說明及服務資訊、產品保證和注意事項。

**註：**手冊中的圖例與您的硬體可能略有不同。

有關配接卡硬體資訊、驅動程式安裝程序和進階功能的詳細資訊，請參閱 CD-ROM 的 \info 目錄下相關說明檔案的內容；如需有關驅動程式安裝作業的相關資訊，請參閱 drivers.htm 檔案的內容。

---

## 為您的選用設備註冊

感謝您購買 OPTIONS by IBM。請用一點時間為產品註冊，並提供一些相關資訊，這將幫助 IBM 在未來提供您更好的服務。您的回應在開發對您相當重要的產品和服務時會很有價值，並且能提供更好的溝通管道。您可以在下列 IBM 網站註冊您的選用設備：

<http://www.ibm.com/pc/register>

除非您在網站上的問卷指出，您不想收到進一步的資訊，否則 IBM 會提供您所註冊的產品的資訊及更新。





---

## 安裝及使用手冊

本手冊提供您安裝及使用 IBM<sup>®</sup> 10/100 乙太網路桌面配接卡所需的相關資訊。

---

### 系統需求

在安裝配接卡之前，請檢查您的電腦是否符合下列的配置需求：

- 一個可用的 32 位元 PCI 插槽。
- 電腦中有最新的 BIOS。
- Microsoft<sup>®</sup> Windows<sup>®</sup> 2000 Professional、Microsoft Windows NT<sup>®</sup> 4.0 Workstation、Windows Millennium Edition (Me)、Windows 98、Windows 95、Novell NetWare 3x 或更新版本、Linux、Solaris、UnixWare，或是 DOS。
- Windows NT - Service Pack 5 或更新版本。
- 對 NetWare 而言，須更新成最新版的 NetWare - Support Pack 版本；該片光碟中含有必要的 NLM 元件。

請從 Microsoft 和 Novell 的網站下載所需的軟體。

### Microsoft Service Pack

請前往下列 Microsoft 網站以取得最新版的 Service Pack 資訊：  
<http://www.microsoft.com/ntserver>；如果該網站的網址已變更，請至 Microsoft 的主網站，並使用 'service Pack' 為關鍵字進行搜尋。

### Novell NetWare Support Pack

請前往下列 Novell 網站以取得最新版的 Support Pack 資訊：  
<http://support.novell.com/misc/patlst.htm>。

## 安裝配接卡

1. 關閉電腦及所有附屬裝置的電源，並拔掉電腦及附屬裝置上所有的接線。  
**警告：** 在移除電腦外殼之前，請先關閉電腦並拔掉電腦上的接線。如果沒有執行這個步驟，則您可能會有觸電的危險，並可能損壞配接卡、電腦，或兩者；
2. 將未使用的 32 位元插槽上的螺絲取下，並移除其外殼的托架；請確定外殼的托架沒有接觸到主機板上任何正在執行的零組件。
3. 如果您要啓用 Wake on LAN<sup>®</sup> 這這項功能，則在進行其他步驟之前，請先參閱第1-3頁的『使用 Wake on LAN 的功能』一節的內容。

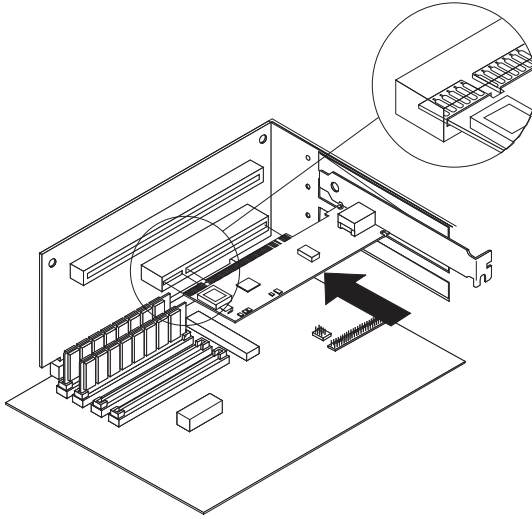

4. 將配接卡推入插槽中，直到配接卡穩固地安裝於插槽中，然後將在步驟 2 中所卸下的螺絲回裝至配接卡托架上，並上緊螺絲。
5. 對所有您要安裝的每一個配接卡重複前述步驟 2 到 4。
6. 回裝電腦外殼、連接所有的接線，然後將電腦的電源線插入電源插座中。
7. 開啓電腦的電源；電腦的 BIOS 會自動指定配接卡的資源。如果發生 PCI 配置錯誤的情況，請參閱「附錄 A」中「PCI 配置疑難排解」一節的相關內容。

## 連接網路接線

將網路接線連接至配接卡上。如果您的網路為 10 Mbps 的網路，請使用 Category 3、4，或 5 等規格的雙絞線乙太網路 (TPE) 接線；如果您的網路為 100 Mbps 的網路，則請使用 Category 5 規格的 TPE 網路接線來連接配接卡。如需詳細資訊，請參閱「附錄 B」。

若要架構配接卡，請參閱第1-5頁的『安裝網路裝置驅動程式』作業系統的說明。

## 連接 Wake on LAN 電源線

**註：** 如果您的系統符合 PCI 2.2 的規格，則不需使用 Wake on LAN 接線；但是，如果在這類系統上連接此接線，也不會有不良的影響。

如果要讓 Wake on LAN 的功能正常運作，須將配接卡連接至可以長久穩定供電的電源上；如此，才能讓配接卡在關閉電腦之後仍然可以繼續監視網路。若要安裝 Wake on LAN 的電源線，請遵循下列的指示進行：

1. 請關閉電腦以及所有連接裝置的電源；將所有的接線從電腦上拔下。
2. 移除電腦的外殼。
3. 找出配接卡上 3-pin 的 Wake on LAN 連接器，如下圖所示，將 Wake on LAN 接線的一端連接至配接卡上。

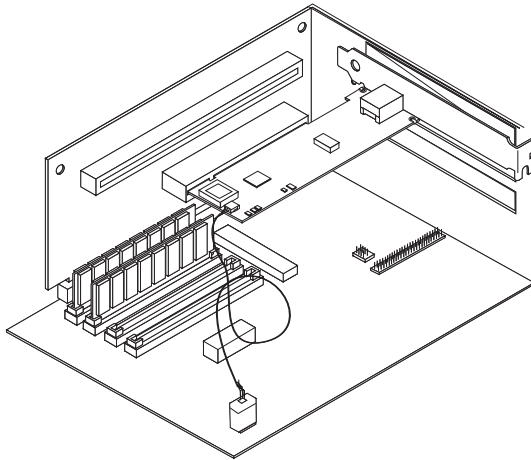

4. 如下圖所示，將 Wake on LAN 接線的另一端連接至主機板上。
5. 部份的電腦可能需要改變電腦的 BIOS 或安裝程式的設定，以啓動 Wake on LAN 的功能。請查閱您電腦附帶的說明文件，以取得更多的相關資訊。
6. 回裝電腦的外殼，並連接所有的接線。

### 使用 Wake on LAN 的功能

Wake on LAN 功能係根據網路配接卡的公佈規格來操作，這些網路配接卡即使在電腦電源關閉時仍可監視網路活動。

即使在關機後，電腦中的其他組件處於沒有電源供應的模式下，Wake on LAN 配接卡卻仍然能以低電源待機的模式繼續運作。該配接卡可以回應由另一部電腦或網路裝置所傳來的起動分封。一般而言，這種起動分封可以讓配接卡發出訊號給電腦，要求其開啓電源，並執行預先定義的程式。

如需有關設定和使用 Wake on LAN 功能的相關資訊，請參閱網路上的 Wake on LAN 簡要資訊，網址為：<http://www.ibm.com/pc/us/infobr/iblan.html>。

如需 Wake on LAN 操作上一般性的疑難排解以及常見問題的解決方案清單，請參閱「附錄 A」中的相關內容。

---

## 安裝網路裝置驅動程式

本章節提供您要在下列作業系統上安裝裝置驅動程式的相關程序：

- Windows 2000 (若為 Windows 95、Windows 98 以及 Windows Me 等作業系統，請參閱線上使用手冊)
- Windows NT 4.0 Workstation
- Novell NetWare 5.x (若為 3.x、4.x 和 DOS 用戶端，請參閱線上使用手冊)
- Linux、Solaris、UnixWare 2.x 及 7.0 (請參閱光碟上的使用手冊)

您可以直接從光碟安裝所需的裝置驅動程式，也可以建立安裝磁片的方式來進行安裝；若要建立安裝磁片，請參閱第1-7頁的『製作磁片』。

### Windows 2000

當您安裝了配接卡、連接接線、插入電源線並啟動電腦之後，Windows 會顯示「找到新的硬體」視窗，並隨之啟動「尋找新硬體精靈」的程式。請遵循下列程序以正確安裝所需的裝置驅動程式。

1. 將 *IBM 10/100 Ethernet* 桌面配接卡系列的光碟插入在光碟機中。如果光碟自動啟動，請先關閉該視窗。
2. 在「歡迎使用」的精靈視窗中，按一下「下一步」。
3. 按一下「搜尋」，然後按一下「下一步」。
4. 在「指定磁碟機」的視窗中，選取「CD-ROM」核取方塊，然後按一下「下一步」。
5. 按一下「下一步」。
6. 按一下「完成」。
7. 重新啟動電腦。

**註：**在 Windows 2000 的環境中，配接卡內容的 PROSet 2 公用程式並不會隨著裝置驅動程式的安裝作業而自動安裝。若要安裝 PROSet 2，請執行下列步驟：

- 在光碟的 Autorun.exe 程式中，跳至「安裝進階功能」的選項。
- 或者，直接執行光碟上 Setup 目錄中的 setup.exe 程式。

### Windows NT 4.0 Workstation

E100NT4.SYS NDIS 4.0 裝置驅動程式可支援 Windows NT 4.0 Workstation；但不支援在 Windows NT 3.51 或更早期版本的環境下使用。

**註：**在您安裝此一裝置驅動程式之前，請先檢視第1-1頁的『系統需求』中有關 Service Pack 的需求。如果您也正在安裝 Windows NT 4.0，您必須先建立安裝驅動程式所需的磁片。相關資訊，請參閱第1-7頁的『製作磁片』。

若要安裝該裝置驅動程式，請遵循下列指示操作：

1. 按一下**開始**，然後按一下**設定**，再按一下**控制台**。
2. 按一下**網路圖示**。

3. 按一下**配接卡**，然後再按一下**新增**。
4. 按一下**從磁碟安裝**
5. 將 *IBM 10/100 Ethernet 桌面配接卡* 系列的光碟插入在光碟機中。
6. 請鍵入您光碟機的路徑，然後按一下**確定**。
7. 請遵循畫面上的指示來安裝裝置驅動程式；新增配接卡之後，會在「網路配接卡」清單中顯示該配接卡。
8. 按一下**確定**，然後按一下**關閉**。然後依照系統的提示，重新啟動電腦。

## Novell NetWare 5.x

**註：**有關 NetWare 伺服器 and 用戶端作業系統，請參閱您光碟上的線上使用手冊。

請使用 NetWare 安裝程式來安裝配接卡的裝置驅動程式（裝置驅動程式名稱：ce100B.LAN 於 \NWSERVER 資料夾中）。有關 Service Pack 的需求資訊，請參閱第1-1頁的『系統需求』中的相關內容。

**註：**在安裝裝置驅動程式之前，請先針對您伺服器的光碟機載入 DOS 或 NetWare 驅動程式，或是先在另一部電腦上使用「IBM 10/100 乙太網路桌面配接卡系列」的光碟建立磁片；相關資訊，請參閱第1-7頁的『製作磁片』。

若要安裝裝置驅動程式，請遵循下列指示操作：

1. 在 NetWare 主控台中，鍵入 nwconfig，然後按下 Enter 鍵。
2. 按一下**驅動程式選項**，然後按下 press 鍵。
3. 按一下**架構網路驅動程式**，然後按下 Enter 鍵。
4. 按一下**載入其他的驅動程式**，然後按下 Enter 鍵。
5. 將 *IBM 10/100 乙太網路桌面配接卡* 系列光碟插入光碟中，或是將您所建立的磁片插入磁碟機中，然後按下 Insert 鍵，以選取**安裝未列示的驅動程式**。
6. 如果您是使用磁片進行安裝，請按下 Enter 鍵；如果是使用光碟，請按下 F3 並指定光碟機代號作為來源路徑。
7. 按下 Enter 鍵以選驅動程式。
8. 按一下**是**，然後按下 Enter 鍵。
9. 若要修改任何裝置驅動程式參數或通訊協定，請按一下**選擇/修改驅動程式參數和通訊協定**，然後按下 Enter 鍵；插槽號碼為一必要參數，而且必須加以指定。如果您有多片配接卡，請指定您所要配置的正確插槽號碼；當您完成裝置驅動程式的架構作業之後，請按一下**儲存參數並載入驅動程式**，然後繼續。

**註：**如果您的電腦中只有一片 IBM 10/100 乙太網路桌面配接卡，則您可以指定該插槽使用任何號碼；驅動程式會自動偵測正確的插槽號碼，並順利載入。

如果您的系統中存在有一個以上的 IBM 10/100 乙太網路桌面配接卡，請按下 Alt+Esc 組合鍵切換至 Netware 中的主控台畫面，然後找出配接卡使

用的有效插槽號碼。請鍵入 10AD CE100，然後按下 Enter 鍵。裝置驅動程式會試著進行載入，並會提示您可用的插槽號碼；請抄下所提示的插槽號碼，然後按下 Esc 鍵，停止驅動程式的載入作業。再按下組合鍵 Alt+Esc，切換回到「安裝」視窗中，然後填入正確的插槽號碼。

10. 在安裝裝置驅動程式的視窗中，一直按下 Esc 鍵直到顯示「架構選項」的視窗，然後遵循螢幕上的指示操作。
11. 按一下**結束**，回到伺服器主控台提示的畫面。
12. 如果您正在安裝數片配接卡，請對伺服器中的每一個新的配接卡重複裝置驅動程式的安裝程序。

**註：**如果安裝作業完成後，配接卡仍然無法運作時，則您可能必須要修改資訊框類型，或是 AUTOEXEC.NCF 檔案中 LOAD 和 BIND 的敘述。

## 其它的作業系統

如需有關在其他作業系統上安裝網路裝置驅動程式的指示說明，請查閱 \info 目錄中的說明資訊，或者是位於其所屬裝置驅動程式目錄中 README 檔案的內容。

---

## 製作磁片

如果您必須使用磁片才能安裝配接卡的裝置驅動程式，請執行適用於作業系統的 makedisk.bat 公用程式；下列公用程式位於 *IBM 10/100 乙太網路桌面配接卡系列* 光碟的根目錄中：

Windows NT 4.0	MAKENT.BAT
Windows 2000	MAKEW2K.BAT
Windows 9x	MAKEW9X.BAT
NetWare 4.x and 5.x	MAKENW.BAT

如需這項公用程式的詳細資訊，請參閱 *IBM 10/100 乙太網路配接卡配接卡系列* 光碟根目錄中的 Readme.txt 檔案。

---

## 附加的安裝及配置

「IBM 10/100 乙太網路桌面配接卡系列」可以支援許多網路的進階功能：

**虛擬 LAN：**建立工作群組的 VLAN 以增進網路的安全性和效率。

**PROSet 2：**您可以使用這個公用程式來架構配接卡。

**管理特性：**架構 Wake on LAN 和 Boot Agent.

**優先順序分封 (Priority Packet)：**您可以使用這些功能來設定網路資訊流量的優先順序過濾程式。

**分封保護 (Packet Protect)**：使用此一暗碼化（加密）公用程式來保護區域網路中 IP 流量的機密性與授權認證作業。

如需上述各項功能的相關資訊，請參閱光碟上 \info 目錄中的相關資料。



## 附錄A. 疑難排解

本附錄說明了處理一般問題的方法。

### 1. 檢查配接卡上的 LED 指示燈。

如果 LINK 燈並未亮起，請檢查配接卡以及相關連線裝置上所有的連線狀況，請確定已將相關連線裝置設定為 100 Mbps 和全雙工，而且已執相關的裝置驅動程式。

### 2. 請確定接線已正確安裝。

網路接線必須緊固地安裝於所有的連線接頭上；如果已正確連結接線，但問題仍然存在，請使用另一條接線。

### 3. 測試配接卡。

在 DOS 模式下，使用 diag100.exe 程式執行配接卡與網路測試（該程式位於 IBM 10/100 乙太網路桌面配接卡光碟上的根目錄中）。

### 4. 查看下表中是否有可以解決您所遭遇問題的解決方案。

如果表中所提供的步驟無法解決您所遭遇的問題，請參閱「附錄 C」。

問題	解決方案
電腦找不到配接卡	<ul style="list-style-type: none"><li>請確定配接卡已緊固地插入插槽中。</li><li>嘗試使用另一個 PCI Busmaster 插槽；請參閱伺服器說明文件以識別哪些插槽為 Busmaster 的插槽。</li><li>使用另一片 IBM 10/100 乙太網路配接卡。</li></ul>
分析正常但無法進行連線	<ul style="list-style-type: none"><li>請試著執行「傳送-回應」(Sender-Responder) 分析測試。</li><li>請確定網路接線已緊固地連接。</li></ul>
在安裝 IBM 10/100 乙太網路系列配接卡之後，配接卡卻停止運作	<ul style="list-style-type: none"><li>請確定是將接線連接至 IBM 10/100 乙太網路配接卡上，而不連接至其他的配接卡。</li><li>請檢查是否有資源衝突的情況；相關資訊，請參閱第A-2頁的『PCI 架構設定的疑難排解』。</li><li>請確定兩片配接卡均已緊固地插入插槽中。</li><li>檢查所有接線。</li></ul>
配接卡因不明原因停止運作。	<ul style="list-style-type: none"><li>請試著重新插入配接卡</li><li>有可能是網路裝置驅動程式已損壞或是遭到誤刪。請試著重新安裝裝置驅動程式。</li><li>嘗試使用另一片 IBM 10/100 乙太網路配接卡</li><li>請嘗試啟動或停用對應連接裝置上的自動協議 (Auto-negotiation) 設定（此一設定值在切換器和配接卡上必須設定一致）。</li></ul> <p>註：即使配接卡與其對應連接裝置之間的通訊並未正常建立，配接卡上的 LNK LED 指示燈卻仍然亮起；請檢查對應連接裝置上的架構設定值；包含雙方是否均已設定為自動協議 (Auto-negotiate)，以及雙方的速度與雙工的設定是否一致。</p>

問題	解決方案
LNK LED 指示燈不會亮起。	<ul style="list-style-type: none"> <li>請確定您已安裝了該配接卡的裝置驅動程式。</li> <li>檢查配接卡或切換器上的所有接線。</li> <li>請嘗試使用「緩衝中繼器」(Buffered Repeater) 或切換器上的另一個連接埠。</li> <li>請嘗試啟動或停用對應連接裝置上的自動協議 (Auto-negotiation) 設定 (此一設定值在切換器和配接卡上必須設定一致)。</li> </ul>
無法使用 Wake on LAN 的功能。	<ul style="list-style-type: none"> <li>請確定已連接 Wake on LAN 的接線，而且電腦的電源線已連接至功能正常的電源插座上。</li> <li>檢查 BIOS 中 Wake on LAN 的設定值；某些電腦必須要進行一些架構的設定作業，才能使用 Wake on LAN 的功能。請參閱隨附於您電腦的說明文件。</li> <li>請檢查網路接線已完全插入配接卡中。</li> </ul>

## PCI 架構設定的疑難排解

某些 PCI 的電腦必須執行額外的設定步驟，才能架構 PCI 配接卡；如果您遇到設定配接卡架構的問題，請試著使用下列的方法排除問題。

- 停用 BIOS 中「隨插即用」的功能；對某些電腦而言，如果資源分配不當，可能必須使用 BIOS 設定程式才能停用「隨插即用」(Plug and Play)。
- 啟用 PCI 插槽；對某些電腦而言，您可能必須使用 BIOS 設定程式才能啟用 PCI 插槽的功能。尤其是使用 PhoenixBIOS 程式碼的一般 PCI 電腦。
- 啟用 Busmaster 的插槽。您必須將「IBM 10/100 乙太網路桌面配接卡」安裝於 Busmaster 的插槽中；某些 BIOS 的設定程式會要求您將插槽啟用為 Busmaster/Master 的模式。請檢查您的 BIOS 設定程式以及電腦說明文件，以確定該插槽是否已設定為 Busmaster/Master 的模式。
- 設定該插槽的「層級觸發中斷」(Level-Triggered Interrupt) 的架構。該配接卡所使用的 PCI 插槽必須設定為「層級觸發中斷」(Level-Triggered Interrupt)，而不是設定為「排擠觸發中斷」(Edge-Triggered Interrupt)。請檢查「BIOS 設定程式」已將該插槽設定為「層級觸發」。
- 保留 ISA 配接卡的中斷向量和記憶體位址；如此可以防止 PCI 配接卡嘗試使用與 ISA 配接卡相同的設定值。請檢查「BIOS 設定程式」；其中可能有像是啟用 ISA 或停用 PCI 的 IRQ 選項供您設定使用。

以下就是一些「BIOS 設定程式」的參數範例：

PCI 插槽編號： 安裝配接卡的插槽 (1-3)  
主要 (Master)： 啓用  
附屬 (Slave)： 啓用  
潛伏 (延遲) 計時器 40 - 80  
中斷 (向量)： 請從 BIOS 設定程式所提供的項目中選擇一個  
排擠 / 層級 (Edge/Level)： 層級 (Level)

不同的電腦中相同的參數可能會使用不同的名詞。

---

## 軟體更新網站

如需 Microsoft 和 Novell 的更新軟體，請自行至下列網站下載：

- **Microsoft Service Pack 5:**  
<ftp://ftp.microsoft.com/bussys/winnt/winnt-public/fixes/usa/nt40/ussp5/>
- **Microsoft Service Pack 4:**  
<ftp://ftp.microsoft.com/bussys/winnt/winnt-public/fixes/usa/nt40/ussp4/>
- **Microsoft Service Pack 3:**  
<ftp://ftp.microsoft.com/bussys/winnt/winnt-public/fixes/usa/nt40/ussp3/>
- **Microsoft NDIS Driver Hotfix:**  
<ftp://ftp.microsoft.com/bussys/winnt/winnt-public/fixes/usa/nt40/hotfixes-postsp3/ndis-fix/>
- **Novell Support Pack 6 for NetWare 4.11 或 Support Pack 1 for NetWare 5.0:**<http://support.novell.com/misc/patlst.htm>



## 附錄B. 配接卡規格

相容性	PCI v2.2 系統
媒體（接線）接頭與線路	<ul style="list-style-type: none"><li>• RJ-45</li><li>• 在 100 Mbps 時，請使用 Category 5 類型的電纜</li><li>• 支援 100BASE-TX TX Fast 乙太網路</li></ul>
資料傳送率模式	10 或 100 Mbps
中斷層次	PCI: INTA（適用於乙太網路 10/100 雙連接埠伺服器配接卡的 INTA 與 INTB）
SRAM 傳輸/接收緩衝區	6 KB
電源需求	直流 +5 伏特，電流 300 毫安（1.5 瓦特）；（10/100 雙連接埠伺服器配接卡的電壓為直流 5 伏特時，則功率為 3 瓦特）
中斷	PCI: INTA（適用於 10/100 雙連接埠伺服器配接卡的 INTA 與 INTB）
LED	連結/動作
尺寸	5.1 公分 x 11.9 公分（2 英吋 x 4.7 英吋）；不含托架
作業溫度	0° 至 55° C（32° 至 131° F）
濕度	10% 至 90%；非凝結
符合下列標準之規格	IEEE 802.3、IEEE 802.3x、IEEE 802.1p、IEEE 802.1q
分析軟體	<ul style="list-style-type: none"><li>• 內建</li><li>• PROSet</li><li>• Responder</li></ul>
安規與認證	<ul style="list-style-type: none"><li>• 安全標準 - UL</li><li>• FCC Class B</li><li>• CE 和 Immunity</li><li>• C-tick（限澳洲）</li></ul>
雙工模式 (Duplex Mode)	全雙工/半雙工



---

## 附錄C. Help and service

This section contains information on how to obtain online and telephone technical support.

---

### Online technical support

Online technical support is available during the life of your product. Online assistance can be obtained through the Personal Computing Support Web site and the IBM Automated Fax System.

<i>Online technical support</i>	
IBM Personal Computing Support Web site	<a href="http://www.ibm.com/pc/support">http://www.ibm.com/pc/support</a>
IBM Automated Fax System	1-800-426-3395 (U.S. and Canada)

During the warranty period, assistance for replacement or exchange of defective components is available. In addition, if your IBM option is installed in an IBM computer, you might be entitled to service at your location. Your technical support representative can help you determine the best alternative.

---

### Telephone technical support

Installation and configuration support through the HelpCenter will be withdrawn or made available for a fee, at IBM's discretion, 90 days after the option has been withdrawn from marketing. Additional support offerings, including step-by-step installation assistance, are available for a nominal fee.

To assist the technical support representative, have available as much of the following information as possible:

- Option name
- Option number
- Proof of purchase
- Computer manufacturer, model, serial number (if IBM), and manual
- Exact wording of the error message (if any)
- Description of the problem
- Hardware and software configuration information for your system

If possible, be at your computer. Your technical support representative might want to walk you through the problem during the call.

For the support telephone number and support hours by country, refer to the following table or to the enclosed technical support insert. Support phone numbers are also available by clicking **HelpCenter phone list** on the IBM support Web page at

<http://www.ibm.com/pc/support>

If the number is not provided, contact your IBM reseller or IBM marketing representative. Response time might vary depending on the number and nature of the calls received.

<b><i>Support 24 hours a day, 7 days a week</i></b>	
Canada (Toronto only)	416-383-3344
Canada (all other)	1-800-565-3344
U.S.A. and Puerto Rico	1-800-772-2227



---

## 附錄D. Product warranty and notices

This section contains the warranty period for your product and the IBM Statement of Limited Warranty.

**Machine** - 10/100 Desktop Adapters **Warranty period\*** - One Year

*\* Contact your place of purchase for warranty service information. Some IBM Machines are eligible for on-site warranty service depending on the country where service is performed.*

---

## IBM Statement of Limited Warranty

### Part 1 - General Terms

This Statement of Limited Warranty includes Part 1 - General Terms and Part 2 - Country-unique Terms. The terms of Part 2 replace or modify those of Part 1. The warranties provided by IBM in this Statement of Limited Warranty apply only to Machines you purchase for your use, and not for resale, from IBM or your reseller. The term 『Machine』 means an IBM machine, its features, conversions, upgrades, elements, or accessories, or any combination of them. The term 『Machine』 does not include any software programs, whether pre-loaded with the Machine, installed subsequently or otherwise. Unless IBM specifies otherwise, the following warranties apply only in the country where you acquire the Machine. Nothing in this Statement of Limited Warranty affects any statutory rights of consumers that cannot be waived or limited by contract. If you have any questions, contact IBM or your reseller.

### The IBM Warranty for Machines

IBM warrants that each Machine 1) is free from defects in materials and workmanship and 2) conforms to IBM's Official Published Specifications ( 『Specifications』 ). The warranty period for a Machine is a specified, fixed period commencing on its Date of Installation. The date on your sales receipt is the Date of Installation unless IBM or your reseller informs you otherwise.

If a Machine does not function as warranted during the warranty period, and IBM or your reseller are unable to either 1) make it do so or 2) replace it with one that is at least functionally equivalent, you may return it to your place of purchase and your money will be refunded.

### Extent of Warranty

The warranty does not cover the repair or exchange of a Machine resulting from misuse, accident, modification, unsuitable physical or operating environment, improper

maintenance by you, or failure caused by a product for which IBM is not responsible. The warranty is voided by removal or alteration of Machine or parts identification labels.

**THESE WARRANTIES ARE YOUR EXCLUSIVE WARRANTIES AND REPLACE ALL OTHER WARRANTIES OR CONDITIONS, EXPRESS OR IMPLIED, INCLUDING, BUT NOT LIMITED TO, THE IMPLIED WARRANTIES OR CONDITIONS OF MERCHANTABILITY AND FITNESS FOR A PARTICULAR PURPOSE. THESE WARRANTIES GIVE YOU SPECIFIC LEGAL RIGHTS AND YOU MAY ALSO HAVE OTHER RIGHTS WHICH VARY FROM JURISDICTION TO JURISDICTION. SOME JURISDICTIONS DO NOT ALLOW THE EXCLUSION OR LIMITATION OF EXPRESS OR IMPLIED WARRANTIES, SO THE ABOVE EXCLUSION OR LIMITATION MAY NOT APPLY TO YOU. IN THAT EVENT, SUCH WARRANTIES ARE LIMITED IN DURATION TO THE WARRANTY PERIOD. NO WARRANTIES APPLY AFTER THAT PERIOD.**

### **Items Not Covered by Warranty**

IBM does not warrant uninterrupted or error-free operation of a Machine.

Any technical or other support provided for a Machine under warranty, such as assistance via telephone with 『how-to』 questions and those regarding Machine set-up and installation, will be provided **WITHOUT WARRANTIES OF ANY KIND.**

### **Warranty Service**

To obtain warranty service for a Machine, contact IBM or your reseller. If you do not register your Machine with IBM, you may be required to present proof of purchase.

During the warranty period, IBM or your reseller, if approved by IBM to provide warranty service, provides without charge certain types of repair and exchange service to keep Machines in, or restore them to, conformance with their Specifications. IBM or your reseller will inform you of the available types of service for a Machine based on its country of installation. At its discretion, IBM or your reseller will 1) either repair or exchange the failing Machine and 2) provide the service either at your location or a service center. IBM or your reseller will also manage and install selected engineering changes that apply to the Machine.

Some parts of IBM Machines are designated as Customer Replaceable Units (called 『CRUs』), e.g., keyboards, memory, or hard disk drives. IBM ships CRUs to you for replacement by you. You must return all defective CRUs to IBM within 30 days of your receipt of the replacement CRU. You are responsible for downloading designated Machine Code and Licensed Internal Code updates from an IBM Internet Web site or from other electronic media, and following the instructions that IBM provides.

When warranty service involves the exchange of a Machine or part, the item IBM or your reseller replaces becomes its property and the replacement becomes yours. You represent that all removed items are genuine and unaltered. The replacement may not be new, but will be in good working order and at least functionally equivalent to the item replaced. The replacement assumes the warranty service status of the replaced item. Many features, conversions, or upgrades involve the removal of parts and their return to IBM. A part that replaces a removed part will assume the warranty service status of the removed part.

Before IBM or your reseller exchanges a Machine or part, you agree to remove all features, parts, options, alterations, and attachments not under warranty service.

You also agree to

1. ensure that the Machine is free of any legal obligations or restrictions that prevent its exchange;
2. obtain authorization from the owner to have IBM or your reseller service a Machine that you do not own; and
3. where applicable, before service is provided:
  - a. follow the problem determination, problem analysis, and service request procedures that IBM or your reseller provides;
  - b. secure all programs, data, and funds contained in a Machine;
  - c. provide IBM or your reseller with sufficient, free, and safe access to your facilities to permit them to fulfill their obligations; and
  - d. inform IBM or your reseller of changes in a Machine's location.

IBM is responsible for loss of, or damage to, your Machine while it is 1) in IBM's possession or 2) in transit in those cases where IBM is responsible for the transportation charges.

Neither IBM nor your reseller is responsible for any of your confidential, proprietary or personal information contained in a Machine which you return to IBM or your reseller for any reason. You should remove all such information from the Machine prior to its return.

### **Limitation of Liability**

Circumstances may arise where, because of a default on IBM's part or other liability, you are entitled to recover damages from IBM. In each such instance, regardless of the basis on which you are entitled to claim damages from IBM (including fundamental breach, negligence, misrepresentation, or other contract or tort claim), except for any liability that cannot be waived or limited by applicable laws, IBM is liable for no more than

1. damages for bodily injury (including death) and damage to real property and tangible personal property; and

2. the amount of any other actual direct damages, up to the charges (if recurring, 12 months' charges apply) for the Machine that is subject of the claim. For purposes of this item, the term 『Machine』 includes Machine Code and Licensed Internal Code.

This limit also applies to IBM's suppliers and your reseller. It is the maximum for which IBM, its suppliers, and your reseller are collectively responsible.

**UNDER NO CIRCUMSTANCES IS IBM LIABLE FOR ANY OF THE FOLLOWING: 1) THIRD-PARTY CLAIMS AGAINST YOU FOR DAMAGES (OTHER THAN THOSE UNDER THE FIRST ITEM LISTED ABOVE); 2) LOSS OF, OR DAMAGE TO, YOUR RECORDS OR DATA; OR 3) SPECIAL, INCIDENTAL, OR INDIRECT DAMAGES OR FOR ANY ECONOMIC CONSEQUENTIAL DAMAGES, LOST PROFITS OR LOST SAVINGS, EVEN IF IBM, ITS SUPPLIERS OR YOUR RESELLER IS INFORMED OF THEIR POSSIBILITY. SOME JURISDICTIONS DO NOT ALLOW THE EXCLUSION OR LIMITATION OF INCIDENTAL OR CONSEQUENTIAL DAMAGES, SO THE ABOVE LIMITATION OR EXCLUSION MAY NOT APPLY TO YOU.**

## **Governing Law**

Both you and IBM consent to the application of the laws of the country in which you acquired the Machine to govern, interpret, and enforce all of your and IBM's rights, duties, and obligations arising from, or relating in any manner to, the subject matter of this Agreement, without regard to conflict of law principles.

## **Part 2 - Country-unique Terms**

### **AMERICAS**

#### **BRAZIL**

**Governing Law:** *The following is added after the first sentence:* Any litigation arising from this Agreement will be settled exclusively by the court of Rio de Janeiro.

#### **NORTH AMERICA**

**Warranty Service:** *The following is added to this Section:* To obtain warranty service from IBM in Canada or the United States, call 1-800-IBM-SERV (426-7378).

#### **CANADA**

**Governing Law:** *The following replaces 『laws of the country in which you acquired the Machine』 in the first sentence:* laws in the Province of Ontario.

#### **UNITED STATES**

**Governing Law:** *The following replaces 『laws of the country in which you acquired the Machine』 in the first sentence: laws of the State of New York.*

## **ASIA PACIFIC**

### **AUSTRALIA**

**The IBM Warranty for Machines:** *The following paragraph is added to this Section: The warranties specified in this Section are in addition to any rights you may have under the Trade Practices Act 1974 or other similar legislation and are only limited to the extent permitted by the applicable legislation.*

**Limitation of Liability:** *The following is added to this Section: Where IBM is in breach of a condition or warranty implied by the Trade Practices Act 1974 or other similar legislation, IBM's liability is limited to the repair or replacement of the goods or the supply of equivalent goods. Where that condition or warranty relates to right to sell, quiet possession or clear title, or the goods are of a kind ordinarily acquired for personal, domestic or household use or consumption, then none of the limitations in this paragraph apply.*

**Governing Law:** *The following replaces 『laws of the country in which you acquired the Machine』 in the first sentence: laws of the State or Territory.*

### **CAMBODIA, LAOS, AND VIETNAM**

**Governing Law:** *The following replaces 『laws of the country in which you acquired the Machine』 in the first sentence: laws of the State of New York.*

*The following is added to this Section: Disputes and differences arising out of or in connection with this Agreement shall be finally settled by arbitration which shall be held in Singapore in accordance with the rules of the International Chamber of Commerce (ICC). The arbitrator or arbitrators designated in conformity with those rules shall have the power to rule on their own competence and on the validity of the Agreement to submit to arbitration. The arbitration award shall be final and binding for the parties without appeal and the arbitral award shall be in writing and set forth the findings of fact and the conclusions of law.*

All proceedings shall be conducted, including all documents presented in such proceedings, in the English language. The number of arbitrators shall be three, with each side to the dispute being entitled to appoint one arbitrator.

The two arbitrators appointed by the parties shall appoint a third arbitrator before proceeding upon the reference. The third arbitrator shall act as chairman of the proceedings. Vacancies in the post of chairman shall be filled by the president of the ICC. Other vacancies shall be filled by the respective nominating party. Proceedings shall continue from the stage they were at when the vacancy occurred.

If one of the parties refuses or otherwise fails to appoint an arbitrator within 30 days of the date the other party appoints its, the first appointed arbitrator shall be the sole arbitrator, provided that the arbitrator was validly and properly appointed.

The English language version of this Agreement prevails over any other language version.

## **HONG KONG AND MACAU**

**Governing Law:** *The following replaces 『laws of the country in which you acquired the Machine』 in the first sentence: laws of Hong Kong Special Administrative Region.*

## **INDIA**

**Limitation of Liability:** *The following replaces items 1 and 2 of this Section:*

1. liability for bodily injury (including death) or damage to real property and tangible personal property will be limited to that caused by IBM's negligence;
2. as to any other actual damage arising in any situation involving nonperformance by IBM pursuant to, or in any way related to the subject of this Statement of Limited Warranty, IBM's liability will be limited to the charge paid by you for the individual Machine that is the subject of the claim.

## **JAPAN**

**Governing Law:** *The following sentence is added to this Section: Any doubts concerning this Agreement will be initially resolved between us in good faith and in accordance with the principle of mutual trust.*

## **NEW ZEALAND**

**The IBM Warranty for Machines:** *The following paragraph is added to this Section:*

The warranties specified in this Section are in addition to any rights you may have under the Consumer Guarantees Act 1993 or other legislation which cannot be excluded or limited. The Consumer Guarantees Act 1993 will not apply in respect of any goods which IBM provides, if you require the goods for the purposes of a business as defined in that Act.

**Limitation of Liability:** *The following is added to this Section: Where Machines are not acquired for the purposes of a business as defined in the Consumer Guarantees Act 1993, the limitations in this Section are subject to the limitations in that Act.*

## **PEOPLE'S REPUBLIC OF CHINA (PRC)**

**Governing Law:** *The following replaces this Section: Both you and IBM consent to the application of the laws of the State of New York (except when local law requires otherwise) to govern, interpret, and enforce all your and IBM's rights, duties, and*

obligations arising from, or relating in any manner to, the subject matter of this Agreement, without regard to conflict of law principles.

Any disputes arising from or in connection with this Agreement will first be resolved by friendly negotiations, failing which either of us has the right to submit the dispute to the China International Economic and Trade Arbitration Commission in Beijing, the PRC, for arbitration in accordance with its arbitration rules in force at the time. The arbitration tribunal will consist of three arbitrators. The language to be used therein will be English and Chinese. An arbitral award will be final and binding on all the parties, and will be enforceable under the Convention on the Recognition and Enforcement of Foreign Arbitral Awards (1958).

The arbitration fee will be borne by the losing party unless otherwise determined by the arbitral award.

During the course of arbitration, this Agreement will continue to be performed except for the part which the parties are disputing and which is undergoing arbitration.

## **EUROPE, MIDDLE EAST, AFRICA (EMEA)**

***THE FOLLOWING TERMS APPLY TO ALL EMEA COUNTRIES:*** The terms of this Statement of Limited Warranty apply to Machines purchased from IBM or an IBM reseller.

### **Warranty Service:**

If you purchase an IBM Machine in Austria, Belgium, Denmark, Estonia, Finland, France, Germany, Greece, Iceland, Ireland, Italy, Latvia, Lithuania, Luxembourg, Netherlands, Norway, Portugal, Spain, Sweden, Switzerland or United Kingdom, you may obtain warranty service for that Machine in any of those countries from either (1) an IBM reseller approved to perform warranty service or (2) from IBM. If you purchase an IBM Personal Computer Machine in Albania, Armenia, Belarus, Bosnia and Herzegovina, Bulgaria, Croatia, Czech Republic, Georgia, Hungary, Kazakhstan, Kirghizia, Federal Republic of Yugoslavia, Former Yugoslav Republic of Macedonia (FYROM), Moldova, Poland, Romania, Russia, Slovak Republic, Slovenia, or Ukraine, you may obtain warranty service for that Machine in any of those countries from either (1) an IBM reseller approved to perform warranty service or (2) from IBM.

If you purchase an IBM Machine in a Middle Eastern or African country, you may obtain warranty service for that Machine from the IBM entity within the country of purchase, if that IBM entity provides warranty service in that country, or from an IBM reseller, approved by IBM to perform warranty service on that Machine in that country. Warranty service in Africa is available within 50 kilometers of an IBM authorized service provider. You are responsible for transportation costs for Machines located outside 50 kilometers of an IBM authorized service provider.

## **Governing Law:**

The applicable laws that govern, interpret and enforce rights, duties, and obligations of each of us arising from, or relating in any manner to, the subject matter of this Statement, without regard to conflict of laws principles, as well as Country-unique terms and competent court for this Statement are those of the country in which the warranty service is being provided, except that in 1) Albania, Bosnia-Herzegovina, Bulgaria, Croatia, Hungary, Former Yugoslav Republic of Macedonia, Romania, Slovakia, Slovenia, Armenia, Azerbaijan, Belarus, Georgia, Kazakhstan, Kyrgyzstan, Moldova, Russia, Tajikistan, Turkmenistan, Ukraine, and Uzbekistan, the laws of Austria apply; 2) Estonia, Latvia, and Lithuania, the laws of Finland apply; 3) Algeria, Benin, Burkina Faso, Cameroon, Cape Verde, Central African Republic, Chad, Congo, Djibouti, Democratic Republic of Congo, Equatorial Guinea, France, Gabon, Gambia, Guinea, Guinea-Bissau, Ivory Coast, Lebanon, Mali, Mauritania, Morocco, Niger, Senegal, Togo, and Tunisia, this Agreement will be construed and the legal relations between the parties will be determined in accordance with the French laws and all disputes arising out of this Agreement or related to its violation or execution, including summary proceedings, will be settled exclusively by the Commercial Court of Paris; 4) Angola, Bahrain, Botswana, Burundi, Egypt, Eritrea, Ethiopia, Ghana, Jordan, Kenya, Kuwait, Liberia, Malawi, Malta, Mozambique, Nigeria, Oman, Pakistan, Qatar, Rwanda, Sao Tome, Saudi Arabia, Sierra Leone, Somalia, Tanzania, Uganda, United Arab Emirates, United Kingdom, West Bank/Gaza, Yemen, Zambia, and Zimbabwe, this Agreement will be governed by English Law and disputes relating to it will be submitted to the exclusive jurisdiction of the English courts; and 5) in Greece, Israel, Italy, Portugal, and Spain any legal claim arising out of this Statement will be brought before, and finally settled by, the competent court of Athens, Tel Aviv, Milan, Lisbon, and Madrid, respectively.

## **THE FOLLOWING TERMS APPLY TO THE COUNTRY SPECIFIED:**

### **AUSTRIA AND GERMANY**

**The IBM Warranty for Machines:** *The following replaces the first sentence of the first paragraph of this Section:* The warranty for an IBM Machine covers the functionality of the Machine for its normal use and the Machine's conformity to its Specifications.

*The following paragraphs are added to this Section:*

The minimum warranty period for Machines is six months. In case IBM or your reseller is unable to repair an IBM Machine, you can alternatively ask for a partial refund as far as justified by the reduced value of the unrepaired Machine or ask for a cancellation of the respective agreement for such Machine and get your money refunded.

**Extent of Warranty:** *The second paragraph does not apply.*



**Warranty Service:** *The following is added to this Section:* During the warranty period, transportation for delivery of the failing Machine to IBM will be at IBM's expense.

**Limitation of Liability:** *The following paragraph is added to this Section:* The limitations and exclusions specified in the Statement of Limited Warranty will not apply to damages caused by IBM with fraud or gross negligence and for express warranty.

*The following sentence is added to the end of item 2:* IBM's liability under this item is limited to the violation of essential contractual terms in cases of ordinary negligence.

## EGYPT

**Limitation of Liability:** *The following replaces item 2 in this Section:* as to any other actual direct damages, IBM's liability will be limited to the total amount you paid for the Machine that is the subject of the claim. For purposes of this item, the term 『Machine』 includes Machine Code and Licensed Internal Code.

*Applicability of suppliers and resellers (unchanged).*

## FRANCE

**Limitation of Liability:** *The following replaces the second sentence of the first paragraph of this Section:*In such instances, regardless of the basis on which you are entitled to claim damages from IBM, IBM is liable for no more than: (items 1 and 2 unchanged).

## IRELAND

**Extent of Warranty:** *The following is added to this Section:* Except as expressly provided in these terms and conditions, all statutory conditions, including all warranties implied, but without prejudice to the generality of the foregoing all warranties implied by the Sale of Goods Act 1893 or the Sale of Goods and Supply of Services Act 1980 are hereby excluded.

**Limitation of Liability:** *The following replaces items one and two of the first paragraph of this Section:*1. death or personal injury or physical damage to your real property solely caused by IBM's negligence; and 2. the amount of any other actual direct damages, up to 125 percent of the charges (if recurring, the 12 months' charges apply) for the Machine that is the subject of the claim or which otherwise gives rise to the claim.

*Applicability of suppliers and resellers (unchanged).*

*The following paragraph is added at the end of this Section:* IBM's entire liability and your sole remedy, whether in contract or in tort, in respect of any default shall be limited to damages.

## ITALY

**Limitation of Liability:** *The following replaces the second sentence in the first paragraph:* In each such instance unless otherwise provided by mandatory law, IBM is liable for no more than: 1. (unchanged) 2. as to any other actual damage arising in all situations involving nonperformance by IBM pursuant to, or in any way related to the subject matter of this Statement of Warranty, IBM's liability, will be limited to the total amount you paid for the Machine that is the subject of the claim. *Applicability of suppliers and resellers (unchanged).*

*The following replaces the third paragraph of this Section:* Unless otherwise provided by mandatory law, IBM and your reseller are not liable for any of the following: (items 1 and 2 unchanged) 3) indirect damages, even if IBM or your reseller is informed of their possibility.

## SOUTH AFRICA, NAMIBIA, BOTSWANA, LESOTHO AND SWAZILAND

**Limitation of Liability:** *The following is added to this Section:* IBM's entire liability to you for actual damages arising in all situations involving nonperformance by IBM in respect of the subject matter of this Statement of Warranty will be limited to the charge paid by you for the individual Machine that is the subject of your claim from IBM.

## UNITED KINGDOM

**Limitation of Liability:** *The following replaces items 1 and 2 of the first paragraph of this Section:*

1. death or personal injury or physical damage to your real property solely caused by IBM's negligence;
2. the amount of any other actual direct damages or loss, up to 125 percent of the charges (if recurring, the 12 months' charges apply) for the Machine that is the subject of the claim or which otherwise gives rise to the claim;

*The following item is added to this paragraph:* 3. breach of IBM's obligations implied by Section 12 of the Sale of Goods Act 1979 or Section 2 of the Supply of Goods and Services Act 1982.

*Applicability of suppliers and resellers (unchanged).*

*The following is added to the end of this Section:* IBM's entire liability and your sole remedy, whether in contract or in tort, in respect of any default shall be limited to damages.

---

## Notices

This publication was developed for products and services offered in the U.S.A. IBM may not offer the products, services, or features discussed in this document in other countries. Consult your local IBM representative for information on the products and services currently available in your area. Any reference to an IBM product, program, or service is not intended to state or imply that only that IBM product, program, or service may be used. Any functionally equivalent product, program, or service that does not infringe any IBM intellectual property right may be used instead. However, it is the user's responsibility to evaluate and verify the operation of any non-IBM product, program, or service.

IBM may have patents or pending patent applications covering subject matter described in this document. The furnishing of this document does not give you any license to these patents. You can send license inquiries, in writing, to:

*IBM Director of Licensing  
IBM Corporation  
North Castle Drive  
Armonk, NY 10504-1785  
U.S.A.*

**The following paragraph does not apply to the United Kingdom or any country where such provisions are inconsistent with local law:** INTERNATIONAL BUSINESS MACHINES CORPORATION PROVIDES THIS PUBLICATION 『AS IS』 WITHOUT WARRANTY OF ANY KIND, EITHER EXPRESS OR IMPLIED, INCLUDING, BUT NOT LIMITED TO, THE IMPLIED WARRANTIES OF NON-INFRINGEMENT, MERCHANTABILITY OR FITNESS FOR A PARTICULAR PURPOSE. Some states do not allow disclaimer of express or implied warranties in certain transactions, therefore, this statement may not apply to you.

This information could include technical inaccuracies or typographical errors. Changes are periodically made to the information herein; these changes will be incorporated in new editions of the publication. IBM may make improvements and/or changes in the product(s) and/or the program(s) described in this publication at any time without notice.

IBM may use or distribute any of the information you supply in any way it believes appropriate without incurring any obligation to you.

Any references in this publication to non-IBM Web sites are provided for convenience only and do not in any manner serve as an endorsement of those Web sites. The materials at those Web sites are not part of the materials for this IBM product, and use of those Web sites is at your own risk.

---

## Processing date data

This IBM hardware product and IBM software products that might be packaged with it have been designed, when used in accordance with their associated documentation, to process date data correctly within and between the 20th and 21st centuries, provided all other products (for example, software, hardware, and firmware) used with these products properly exchange accurate date data with them.

IBM cannot take responsibility for the date data processing capabilities of non-IBM products, even if those products are preinstalled or otherwise distributed by IBM. You should contact the vendors responsible for those products directly to determine the capabilities of their products and update them if needed. This IBM hardware product cannot prevent errors that might occur if software, upgrades, or peripheral devices you use or exchange data with do not process date data correctly.

The foregoing is a Year 2000 Readiness Disclosure.

Any performance data contained herein was determined in a controlled environment. Therefore, the result obtained in other operating environments may vary significantly. Some measurements may have been made on development-level systems and there is no guarantee that these measurements will be the same on generally available systems. Furthermore, some measurements may have been estimated through extrapolation. Actual results may vary. Users of this document should verify the applicable data for their specific environment.

---

## Trademarks

The following terms are trademarks of the IBM Corporation in the United States, other countries, or both:

IBM

Wake on LAN

HelpCenter

Microsoft and Windows are trademarks of Microsoft Corporation in the United States, other countries, or both.

Other company, product, and service names may be trademarks or service marks of others.

---

## Electronic emission notices

10/100 Desktop Adapters

## **Federal Communications Commission (FCC) statement**

**Note:** This equipment has been tested and found to comply with the limits for a Class B digital device, pursuant to Part 15 of the FCC Rules. These limits are designed to provide reasonable protection against harmful interference in a residential installation. This equipment generates, uses, and can radiate radio frequency energy and, if not installed and used in accordance with the instructions, may cause harmful interference to radio communications. However, there is no guarantee that interference will not occur in a particular installation. If this equipment does cause harmful interference to radio or television reception, which can be determined by turning the equipment off and on, the user is encouraged to try to correct the interference by one or more of the following measures:

- Reorient or relocate the receiving antenna.
- Increase the separation between the equipment and receiver.
- Connect the equipment into an outlet on a circuit different from that to which the receiver is connected.
- Consult an IBM authorized dealer or service representative for help.

Properly shielded and grounded cables and connectors must be used in order to meet FCC emission limits. Proper cables and connectors are available from IBM authorized dealers. IBM is not responsible for any radio or television interference caused by using other than recommended cables and connectors or by unauthorized changes or modifications to this equipment. Unauthorized changes or modifications could void the user's authority to operate the equipment.

This device complies with Part 15 of the FCC Rules. Operation is subject to the following two conditions: (1) this device may not cause harmful interference, and (2) this device must accept any interference received, including interference that may cause undesired operation.

Responsible party:

International Business Machines Corporation  
New Orchard Road  
Armonk, NY 10504  
Telephone: 1-919-543-2193



Tested To Comply  
With FCC Standards

FOR HOME OR OFFICE USE

## **Industry Canada Class B emission compliance statement**

This Class B digital apparatus complies with Canadian ICES-003.

## **Avis de conformité a la réglementation d'Industrie Canada**

Cet appareil numérique de classe B est conforme à la norme NMB-003 du Canada.

## **Deutsche EMV-Direktive (electromagnetische Verträglichkeit)**

Dieses Gerät ist berechtigt in Übereinstimmung mit dem deutschen EMVG vom 9.Nov.92 das EG-Konformitätszeichen zu führen.

Der Aussteller der Konformitätserklärung ist die IBM UK, Greenock.

Dieses Gerät erfüllt die Bedingungen der EN 55022 Klasse B.

## **European Union - emission directive**

This product is in conformity with the protection requirements of EU Council Directive 89/366/ECC on the approximation of the laws of the Member States relating to electromagnetic compatibility.

IBM can not accept responsibility for any failure to satisfy the protection requirements resulting from a non-recommended modification of the product, including the fitting of non-IBM option cards.

This product has been tested and found to comply with the limits for Class B Information Technology Equipment according to CISPR 22/European Standard EN 55022. The limits for Class B equipment were derived for typical residential environments to provide reasonable protection against interference with licensed communication devices.

## **Union Européenne - Directive Conformité électromagnétique**

Ce produit est conforme aux exigences de protection de la Directive 89/336/EEC du Conseil de l'UE sur le rapprochement des lois des États membres en matière de compatibilité électromagnétique.

IBM ne peut accepter aucune responsabilité pour le manquement aux exigences de protection résultant d'une modification non recommandée du produit, y compris l'installation de cartes autres que les cartes IBM.

Ce produit a été testé et il satisfait les conditions de l'équipement informatique de Classe B en vertu de CISPR22/Standard européen EN 55022. Les conditions pour l'équipement de Classe B ont été définies en fonction d'un contexte résidentiel ordinaire afin de fournir une protection raisonnable contre l'interférence d'appareils de communication autorisés.

## **Unione Europea - Directiva EMC (Conformidad electromagnética)**

Este producto satisface los requisitos de protección del Consejo de la UE, Directiva 89/336/CEE en lo que a la legislación de los Estados Miembros sobre compatibilidad electromagnética se refiere.

IBM no puede aceptar responsabilidad alguna si este producto deja de satisfacer dichos requisitos de protección como resultado de una modificación no recomendada del producto, incluyendo el ajuste de tarjetas de opción que no sean IBM.

Este producto ha sido probado y satisface los límites para Equipos Informáticos Clase B de conformidad con el Estándar CISPR22 y el Estándar Europeo EN 55022. Los límites para los equipos de Clase B se han establecido para entornos residenciales típicos a fin de proporcionar una protección razonable contra las interferencias con dispositivos de comunicación licenciados.

### **Union Europea - Normativa EMC**

Questo prodotto è conforme alle normative di protezione ai sensi della Direttiva del Consiglio dell'Unione Europea 89/336/CEE sull'armonizzazione legislativa degli stati membri in materia di compatibilità elettromagnetica.

IBM non accetta responsabilità alcuna per la mancata conformità alle normative di protezione dovuta a modifiche non consigliate al prodotto, compresa l'installazione di schede e componenti di marca diversa da IBM.

Le prove effettuate sul presente prodotto hanno accertato che esso rientra nei limiti stabiliti per le apparecchiature di informatica Classe B ai sensi del CISPR 22/Norma Europea EN 55022. I limiti delle apparecchiature della Classe B sono stati stabiliti al fine di fornire ragionevole protezione da interferenze mediante dispositivi di comunicazione in concessione in ambienti residenziali tipici.

이 기기는 가정용으로 전자파 적합등록을 기기로서

주거지역에서는 물론 모든 지역에서 사용 할 수 있습니다.

この装置は、情報処理装置等電波障害自主規制協議会（VCCI）の基準に基づきクラスB情報技術装置です。この装置は、家庭環境で使用することを目的としていますが、この装置がラジオやテレビジョン受信機に近接して使用されると、受信障害を引き起こすことがあります。  
取扱説明書に従って正しい取り扱いをして下さい。

**Japanese statement of compliance for products less than or equal to 20 A per phase**

# 高調波ガイドライン適合品







Part Number: 22P4521

Printed in U.S.A.

(1P) P/N: 22P4521

